

Issue Date: 07-30-2008
Revision Date: 02-08-2023
Renewal Date: 02-28-2024

DIVISION: 06 00 00 – WOOD, PLASTICS, AND COMPOSITES
Section: 06 63 00 - Plastic Railings

REPORT HOLDER:
COLOR GUARD, INC.
320 Range Line Rd.
Sheboygan Falls, WI 53085
920-467-8640

REPORT SUBJECT:
Color Guard Vinyl Railing System

- **Classic Series**
- **Architectural Series**
- **Savannah Series**

1.0 SCOPE OF EVALUATION

1.1 This Research Report addresses compliance with the following Codes:

- 2021, 2018, and 2015 *International Building Code*® (IBC)
- 2021, 2018, and 2015 *International Residential Code*® (IRC)

NOTE: This report references 2021 Code sections with [2018 and 2015] Code sections shown in brackets where they differ.

1.2 The *Color Guard Vinyl Railing System* has been evaluated for the following properties (see Table 1):

- Structural Performance
- Durability
- Surface Burning

1.3 The *Color Guard Vinyl Railing System* has been evaluated for the following uses (see Table 1):

- The *Color Guard Vinyl Railing System* is a guardrail under the definitions of the referenced Codes. They are intended for use at or near the open sides of elevated walking areas of buildings and walkways as required by the Codes.
- Guardrail systems recognized in this report may be used in One- and Two-Family Dwellings regulated by the IRC

and all construction types regulated by the IBC in accordance with IBC Sections 705.2.2 and 705.2.3.1 [1406.3], Exceptions 2 and 3. Guardrails less than 42 inches high are limited to use in One- and Two-Family Dwellings (IRC). See Table 1 for additional restrictions based upon Use and Occupancy classification.

2.0 STATEMENT OF COMPLIANCE

The *Color Guard Vinyl Railing System* complies with the Codes listed in Section 1.1, for the properties stated in Section 1.2, and uses stated in Section 1.3, when installed as described in this report, including the Conditions of Use stated in Section 6.0.

3.0 DESCRIPTION

3.1 The *Color Guard Vinyl Railing Systems* are an assemblage of extruded and molded components utilizing Poly Vinyl Chloride (PVC) material produced in the following colors: White, Clay, and Tan.

3.2 The railing systems provide guardrails up to 10 feet (120 inches) in length and a maximum installed height of 42 inches. See Table 1.

3.3 The *Classic Series* and *Architectural Series* systems include an extruded PVC top rail measuring 3 inches wide by 1.5 inches high and an extruded PVC bottom rail measuring 3 inches wide by 2 inches high. Aluminum reinforcement is used in both top and bottom rail members. See Figure 1 through Figure 4, Figure 12, and Figure 13.

3.4 The *Classic Series* system utilizes a square, extruded PVC baluster measuring 1.5 inches by 1.5 inches. See Figure 6.

3.5 The *Architectural Series* system utilizes a molded PVC spindle measuring 1.5 inches by 1.5 inches at its ends. See Figure 7.



3.6 The *Savannah Series* systems include extruded PVC top and bottom rails both measuring 3 inches wide by 2 inches high. Aluminum reinforcement is used in both top and bottom rail members. See Figure 3, Figure 5, and Figure 14.

3.7 The *Savannah Series* system utilizes a square, extruded PVC baluster measuring 1.5 inches by 1.5 inches. See Figure 6.

3.8 All railing systems utilize an intermediate support block installed between the bottom rail and the deck surface midway between the support posts, a 4 inch by 4 inch extruded PVC post sleeve, and PVC rail-mounting brackets.

3.9 The attachment system is designed for mounting the railing to a post or wall with a PVC straight bracket, which may be adapted for angled conditions by utilizing either a PVC 22-1/2° bracket mounting block or a PVC 45° bracket mounting block as permitted in Table 1 with fastening details as described in Table 2. See Figure 8 through 11.

4.0 PERFORMANCE CHARACTERISTICS

4.1 The railing systems described in this report have demonstrated capacity to resist the design loads specified in Chapter 16 of the IBC and Section R301 of the IRC when tested in accordance with ICC-ES AC174.

4.2 Structural performance has been demonstrated for a temperature range from -20°F to 125°F.

4.3 Materials used are deemed equivalent to preservative treated or naturally durable wood for resistance to weathering effects, decay, and attack from termites.

4.4 PVC materials used have a flame spread index less than 200 when tested according to ASTM E 84.

5.0 INSTALLATION

The *Color Guard Vinyl Railing* must be installed in accordance with the manufacturer's published installation instructions, the applicable Code, and this Research Report. A copy of the manufacturer's instructions must be available on the jobsite during installation.

5.1 Guardrail assemblies consist of top and bottom rails with pre-routed holes to receive balusters. Full length aluminum reinforcements are inserted in the rails during assembly.

5.2 The maximum installed span of the guard as measured from the inside edge to the inside edge of the post or wall supports shall not exceed the limits given in Table 1 according to the building use classification.

5.3 Molded PVC brackets are utilized to attach top and bottom rails to a PVC-sleeved conventional 4x4 wood post or other suitable supporting structure. Rail brackets are attached to the supports and rails with stainless steel screws in accordance with the fastening schedule shown in Table 2. The wood in the supporting structure shall have a specific gravity of 0.50 or greater (Southern Yellow Pine or better) and a minimum thickness to allow full penetration of the bracket mounting screws.

6.0 CONDITIONS OF USE

6.1 Installation must comply with this Research Report, the manufacturer's published installation instructions, and the applicable Code. In the event of a conflict, this report governs.

6.2 The use of this product is limited to exterior use in buildings as permitted in Table 1.

6.3 Compatibility of fasteners, metal mount components, and other metal hardware with the supporting construction including chemically treated wood is outside the scope of this report.

6.4 Conventional wood supports (posts or walls) for guards are not within the scope of this report and are subject to evaluation and approval by the building official. Supports must satisfy the design load requirements specified in Chapter 16 of the IBC and must provide suitable material for anchorage of the rail brackets. Where required by the building official, engineering calculations and details prepared by a licensed design professional shall be provided.

6.5 The *Color Guard Vinyl Railing System* is manufactured under a quality program with inspections by Intertek Testing Services NA, Inc.





6.6 Documentation of an Intertek approved quality control system for the manufacturing of products recognized in this report.

7.0 SUPPORTING EVIDENCE

7.1 Drawings and installation instructions submitted by the manufacturer.

7.2 The reports of testing and engineering analysis demonstrating compliance with the performance requirements of ICC-ES AC174, Acceptance Criteria for Deck Board Span Ratings and Guardrail Systems (Guards and Handrails), revised December 2014, and ASTM D 7032-17 [-14, -10a], Standard Specification for Establishing Performance Ratings for Wood-Plastic Composite Deck Boards and Guardrail Systems (Guards or Handrails).

7.3 Documentation of an Intertek approved quality control system for the manufacturing of products recognized in this report.

8.0 IDENTIFICATION

The *Color Guard Vinyl Railing System* is identified with the manufacturer's name (Color Guard, Inc.), address and telephone number, the product name (*Color Guard Vinyl Railing System*), the following statements "See CCRR-0125 at <https://bpdirectory.intertek.com> for uses and performance

levels," and where applicable also "For use in One- and Two-Family Dwellings Only.", the Intertek Mark as shown below, and the Code Compliance Research Report number (CCRR-0125).



9.0 OTHER CODES

This section is not applicable.

10.0 CODE COMPLIANCE RESEARCH REPORT USE

10.1 Approval of building products and/or materials can only be granted by a building official having legal authority in the specific jurisdiction where approval is sought.

10.2 Code Compliance Research Reports shall not be used in any manner that implies an endorsement of the product by Intertek.

10.3 Reference to the <https://bpdirectory.intertek.com> is recommended to ascertain the current version and status of this report.

This Code Compliance Research Report ("Report") is for the exclusive use of Intertek's Client and is provided pursuant to the agreement between Intertek and its Client. Intertek's responsibility and liability are limited to the terms and conditions of the agreement. Intertek assumes no liability to any party, other than to the Client in accordance with the agreement, for any loss, expense or damage occasioned by the use of this Report. Only the Client is authorized to permit copying or distribution of this Report and then only in its entirety, and the Client shall not use the Report in a misleading manner. Client further agrees and understands that reliance upon the Report is limited to the representations made therein. The Report is not an endorsement or recommendation for use of the subject and/or product described herein. This Report is not the Intertek Listing Report covering the subject product and utilized for Intertek Certification and this Report does not represent authorization for the use of any Intertek certification marks. Any use of the Intertek name or one of its marks for the sale or advertisement of the tested material, product or service must first be approved in writing by Intertek.





TABLE 1 – MAXIMUM GUARDRAIL SPANS

System	Type	Maximum Installed Height ²	Code	Maximum Span ¹
<i>Architectural Series</i> and <i>Classic Series</i>	Level	42"	IBC	8'-0"
	Level	36" or 42"	IRC ³	10'-0"
	Level, Angled with 22-1/2° or 45° Bracket Mounting Blocks	36"	IRC	6'-0"
		42"	IBC	6'-0"
<i>Savannah Series</i>	Level	42"	IBC	8'-0"
		36" or 42"	IRC ³	10'-0"

¹ Maximum span is measured from inside to inside of supports (post or wall).

² Railing height is installed height from walking surface to top of top rail.

³ Guardrails with a 42" installed height may also be used under the IBC in the following conditions:

- Detached one- and two-family dwellings and multiple single-family dwellings (townhouses) not more than three stories above grade plane in height with a separate means of egress.

TABLE 2 – FASTENING SCHEDULE

System	Connection	Fastener
<i>Classic Series</i> and <i>Architectural Series</i>	PVC Straight Bracket to PVC-sleeved wood post or PVC Straight Bracket to 22-1/2° or 45° Bracket Mounting Block	Four #10 x 1-1/2 inch self-starting, pan-head screws
	22-1/2° or 45° Bracket Mounting Block to Post	Four #8 x 2-1/2 inch self-starting, pan-head screws
	All PVC brackets to rail ¹	Two #6 x 3/4 inch self-starting, pan-head screws
<i>Savannah Series</i>	PVC Straight Bracket to PVC-sleeved wood post	Four #10 x 1-1/2 inch self-starting, pan-head screws
	PVC Straight bracket to rail ¹	Two #6 x 3/4 inch self-starting, pan-head screws

¹ Fasteners must penetrate the PVC bracket, rail, and aluminum insert.

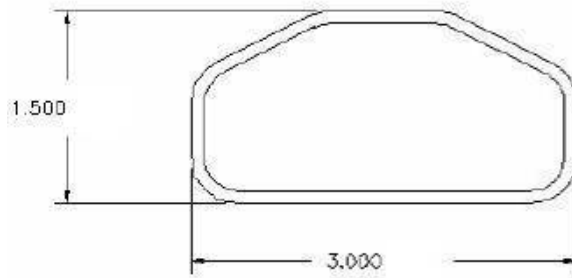

FIGURE 1 – CLASSIC SERIES AND ARCHITECTURAL SERIES TOP RAIL PROFILE

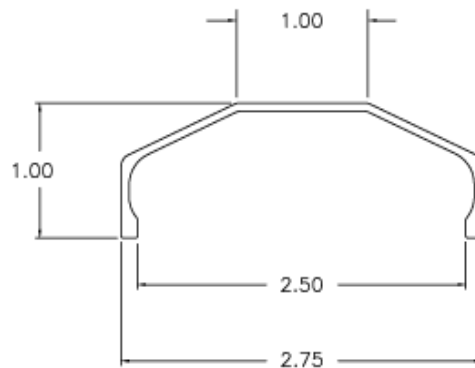

FIGURE 2 – CLASSIC SERIES AND ARCHITECTURAL SERIES TOP RAIL ALUMINUM INSERT

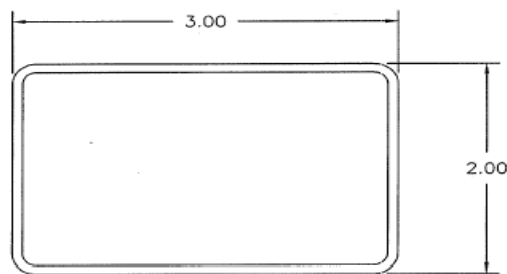

FIGURE 3 – BOTTOM RAIL FOR CLASSIC SERIES AND ARCHITECTURAL SERIES,
TOP AND BOTTOM RAIL FOR SAVANNAH SERIES

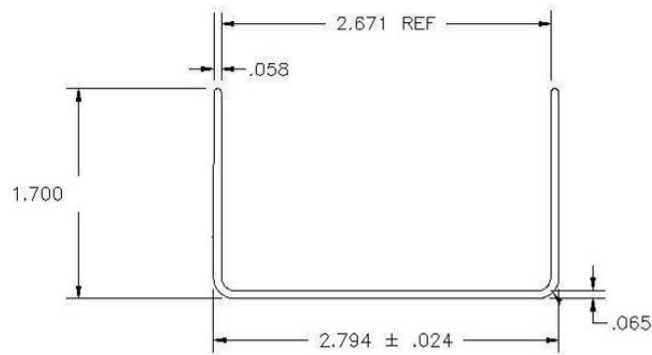

FIGURE 4 – CLASSIC SERIES AND ARCHITECTURAL SERIES BOTTOM RAIL ALUMINUM INSERT

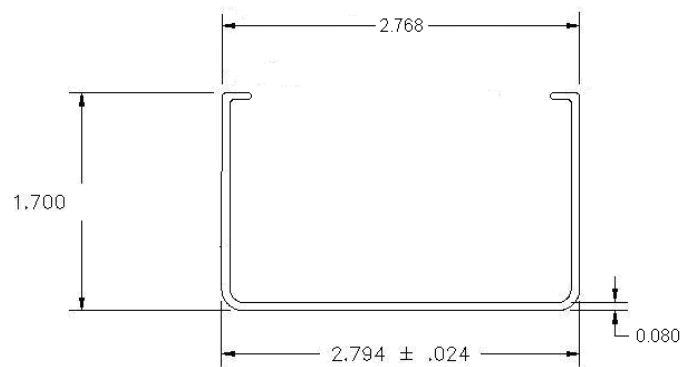

FIGURE 5 –SAVANNAH SERIES TOP AND BOTTOM RAIL ALUMINUM INSERT

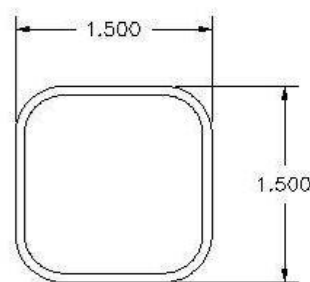

FIGURE 6 –BALUSTER PROFILE: ARCHITECTURAL SERIES, CLASSIC SERIES, AND SAVANNAH SERIES

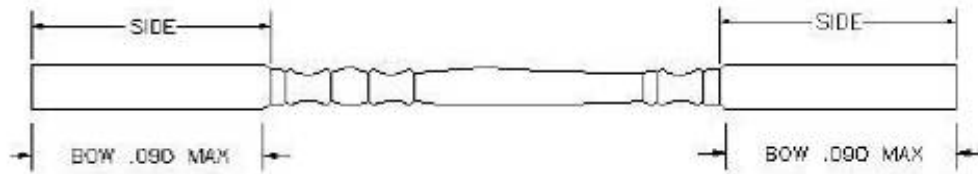

FIGURE 7 – ARCHITECTURAL SERIES SPINDLE

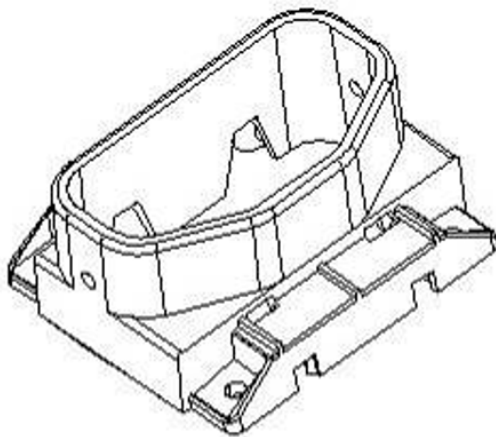

FIGURE 8 – PVC STRAIGHT BRACKET FOR TOP RAIL OF ARCHITECTURAL SERIES AND CLASSIC SERIES

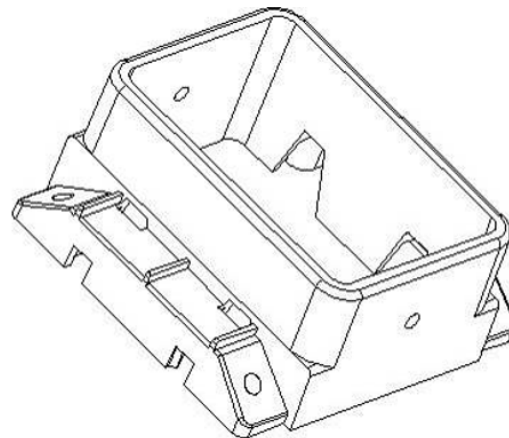

FIGURE 9 – PVC STRAIGHT BRACKET FOR 2" BY 3" PVC RAIL

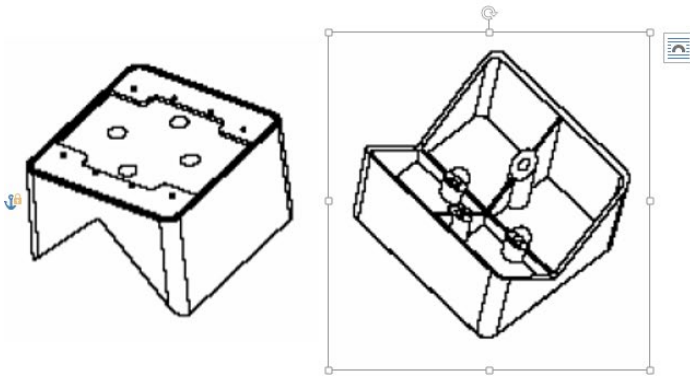

FIGURE 10 – 44° BRACKET MOUNTING BLOCK

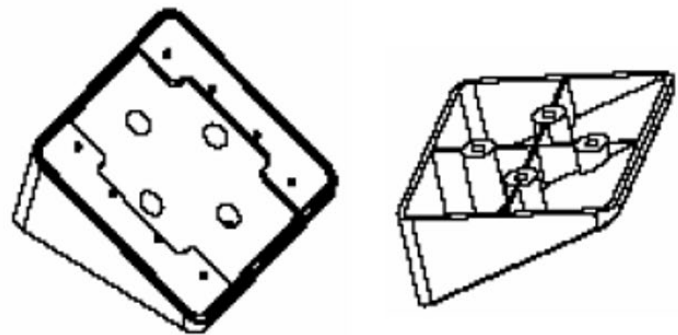

FIGURE 11 – 22.5° BRACKET MOUNTING BLOCK

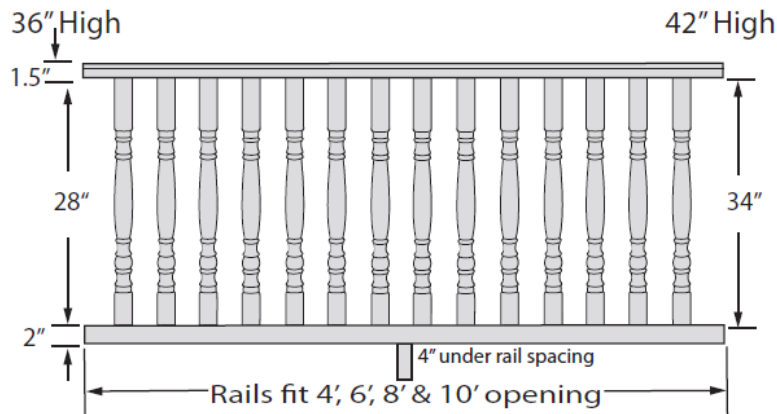

FIGURE 12 – ARCHITECTURAL SERIES

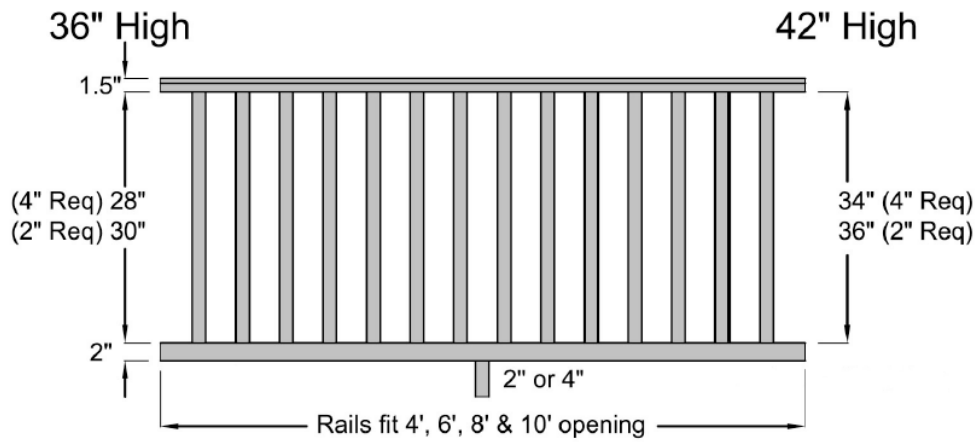

FIGURE 13 – CLASSIC SERIES

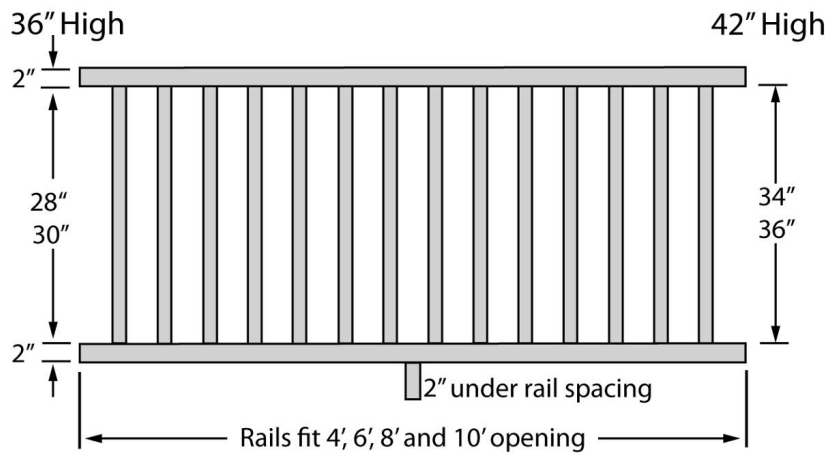

FIGURE 14 – SAVANNAH SERIES

